

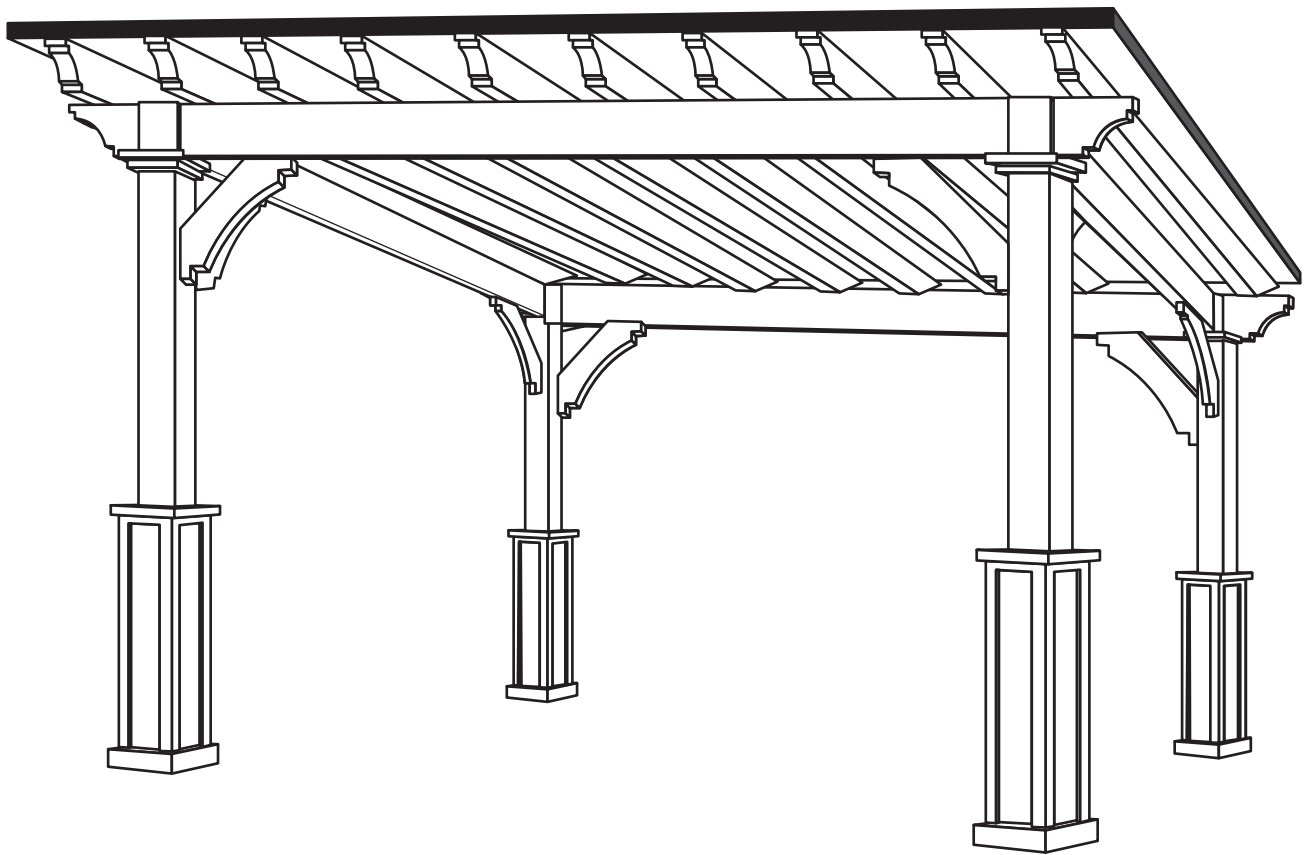

ASSEMBLY INSTRUCTIONS



Shown above is a 10' x 12' Holiday Shadow Pavilion

Thank you for your purchase of a new Holiday Shadow Pavilion. Depending on the size of your Pavilion, installation can usually be completed in 1 to 2 days. These instructions are meant to serve as a guide for people with a base knowledge of general handyman skills. ***This assembly requires a minimum of three people to complete.***

Before You Begin

Please always check with your local building codes, they will vary from state to state.

The base for the Pavilion must be solid and level. If installing on a concrete slab or on concrete footers, they should be level where the posts will rest. If they are not, it may be necessary to cut the bottom of the posts so that the bottoms are all level. Other than this, no cutting is necessary. If you feel that you will need to make any additional cuts, please contact us before doing so. ***Making cuts without calling first may make installation difficult or void our warranties.***

When connecting to concrete, use wedge bolts, which are included in the kit. If connecting to an existing deck, a lag bolt and deck screws (not included) will replace the wedge bolt.

The Pavilion does not give the ability to alter the location of the posts. It is important that they are laid out correctly and double checked for accuracy before permanently attaching it to the base.

NOTE: These instructions are for building a standard, rectangular pavilion. If your pavilion has custom dimensions with a longer gable side or square dimensions with equal sides, this reference point will need to be adjusted appropriately by the builder during installation. CALL WITH ANY QUESTIONS.

Site Preparation

It is important that the site is properly prepared before beginning assembly. It is imperative that the site be level. There are a few choices when installing this structure, the two most common are to anchor the posts to concrete pad/wood decking or attaching to a concrete footer or two Sonotubes. Sinking the posts into the ground is not recommended unless it is called for by your local building codes.

Anchoring the posts to concrete/wood decking, is the most common method and is also the simplest. Please provide a level concrete or wood decking surface, and then lay out the template on the surface. Mark out the squares where the posts and brackets will go. Line up the markings that were made and this is where to set the posts. Posts cannot be anchored into loose pavers or stone. Customer assumes risk if not anchored into concrete or decking joists. This is the method that will be used for the following instructions:

Please check with the local building codes for the depth required for the footers/concrete slab. Also if using concrete footers make sure that all of the tops of the footers are level with each other before starting to build. Contact your Project Advisor with any questions that you may have.

Tools Needed

Hammer drill, hammer, level, tape measure, tin snips, socket set, ladder, circular saw

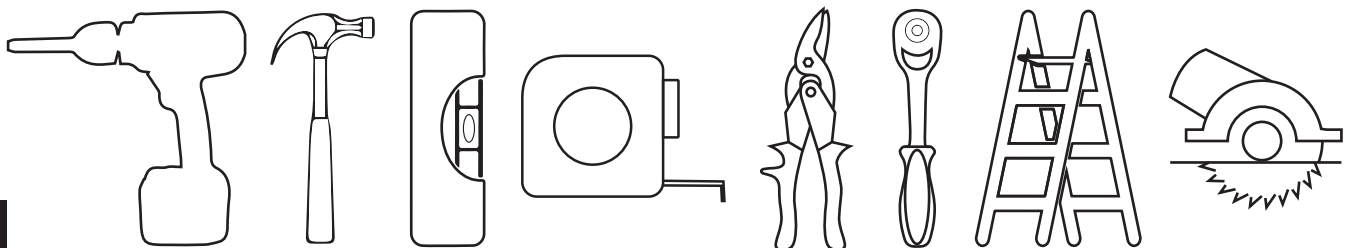

Notes:

There will be a parts list sent with the Pavilion. All hardware is included in each Pavilion kit. The specific hardware will vary depending on the Pavilion. Please see the parts list for details.

1

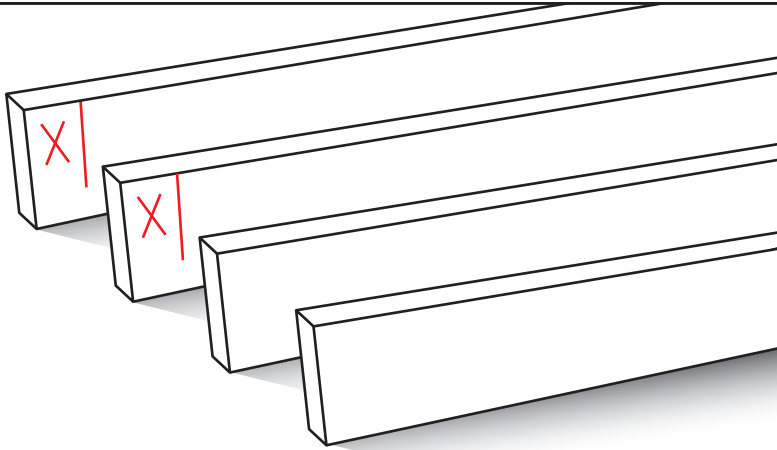

The Pavilion kit includes a wooden template that will be used to mark the post locations. Notice that two of the 2x4 boards have a marking near the ends. Building a box will reveal the outside corners of the posts when properly placed.

Arrange the template pieces so that they are positioned in the exact location of where the Pavilion will be placed. The boards with the marking on the end will be across from each other. The marks will show where the other boards will be attached to create this box.

2

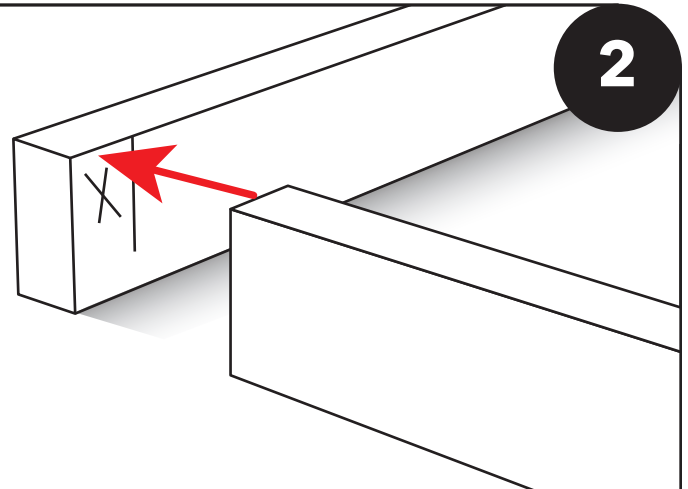

3

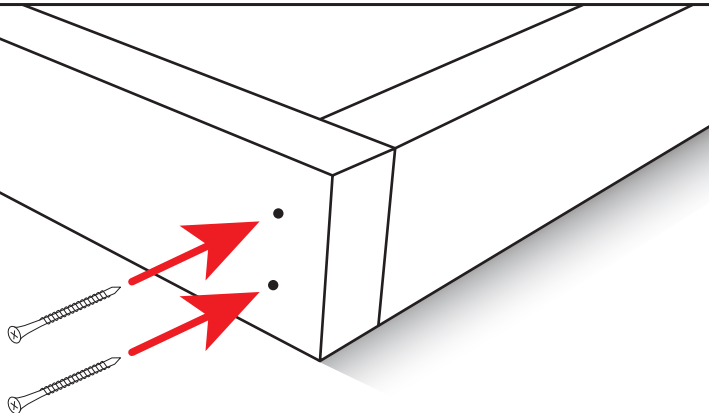

Connect the corners of the template pieces by driving two 2 1/2" screws through the side of the template boards.

3

4

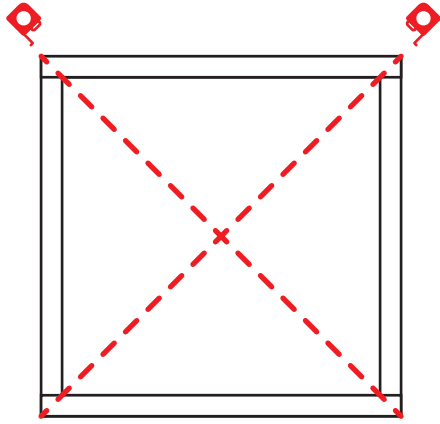

Once the template is in position, square the template. Do this by measuring diagonally from one corner to its opposite corner, then measure diagonally between the other two corners. These two dimensions **MUST** be the same. Adjust the template until the diagonal measurements are identical.

Once the template is "square", mark the post locations using the **INSIDE** corners of the framed box on the concrete slab with a pencil. After all the post locations are marked on the concrete slab, remove and set the wooden template aside.

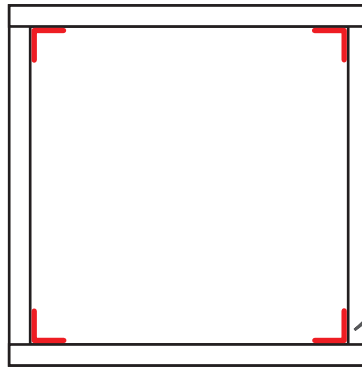

5

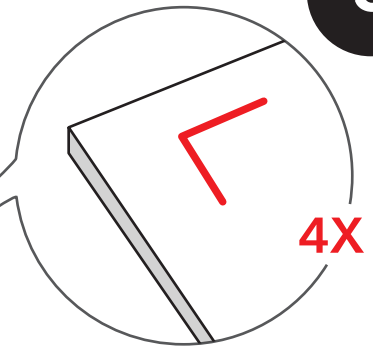

6

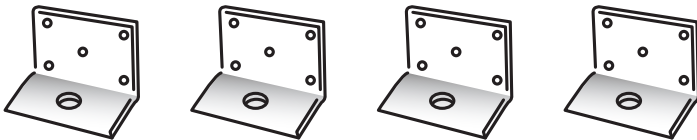

Locate 4 of the 8 L Brackets.

Locate the two highest posts. These posts will be placed where the front of the pavilion is going.

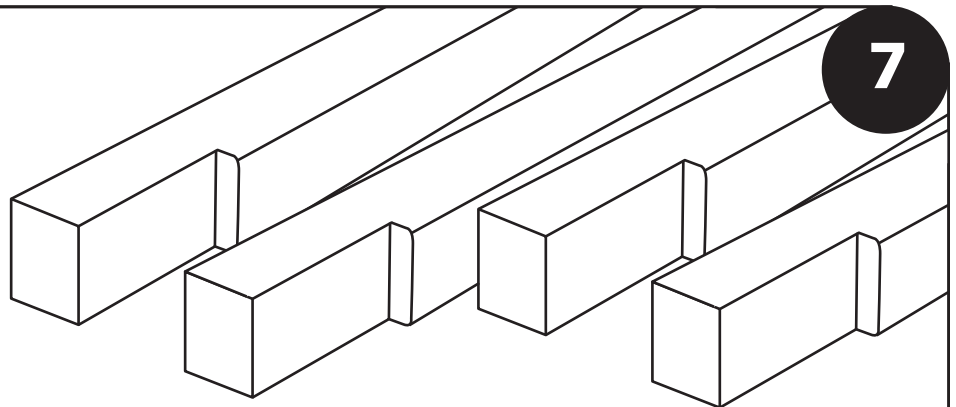

7

8



Place one of the highest posts flush in one of the front corners. Be sure the tallest notched section at the top is facing inward.

While the post is being held in place, perfectly level, attach one L Bracket to the post, centered on the outside of the post at the bottom with five 2 1/2" screws per bracket.

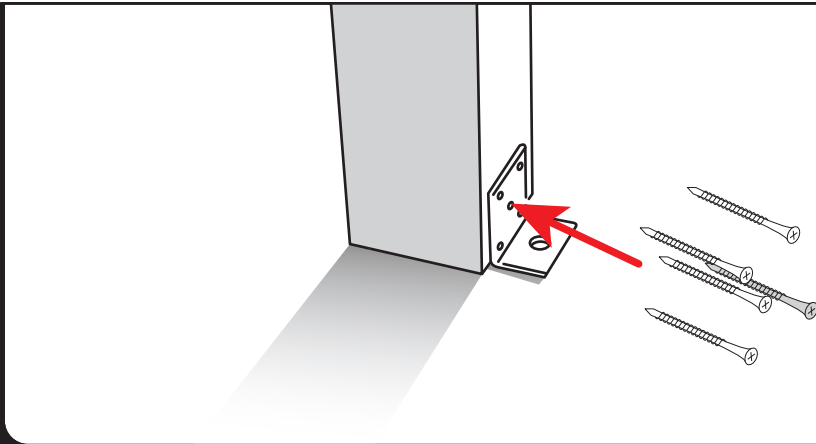

9

10

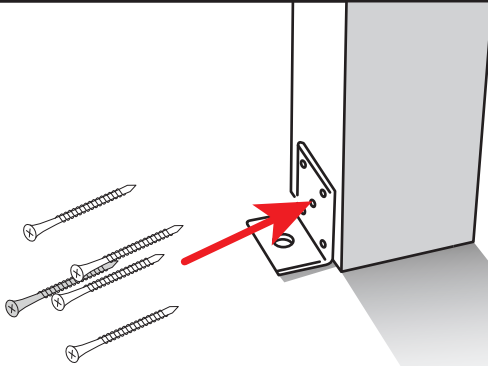

Repeat on all 4 sides. Highest posts in front, shorter posts in back. Be sure all posts have the tallest notch facing inward.

Remove 1 side of the squared template and place around the four posts 5' up.

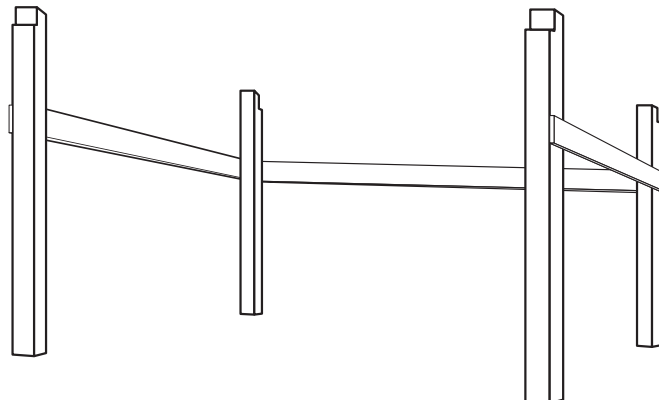

11

12

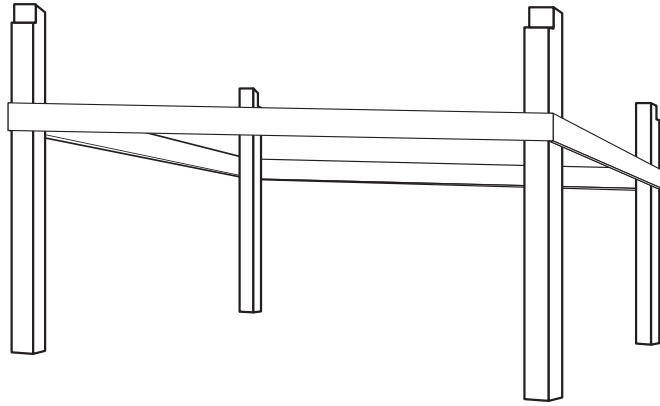

Reattach the fourth side of the template and make sure all posts are square and plumb.

Once square, screw template to posts with one 2 1/2" screw per corner.

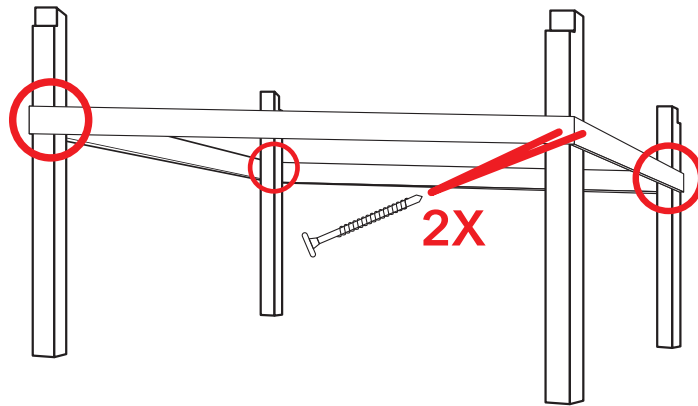

13

14

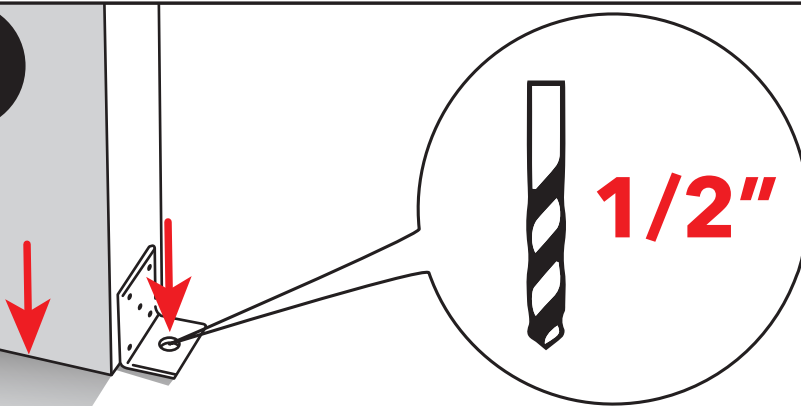

When all posts have an L bracket on, use a drill with 1/2" masonry bit to drill down about 1/2" farther than length of wedge anchor.

Before inserting the bolt, make sure dust is removed from hole. Then screw the nut and washer on about 1/8" below the top of the bolt. Next, insert the wedge anchor bolt into the hole. To protect the threads and nut, tap the bolt into the ground with a piece of wood as a buffer.

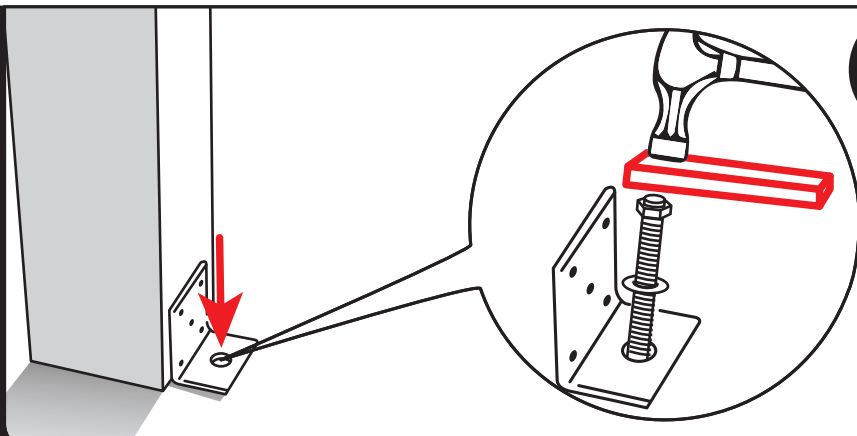

15

16

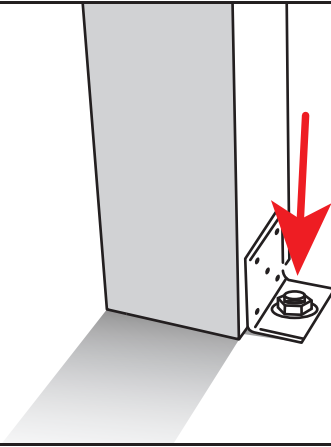

Once the wedge anchor is down against the bracket use a wrench and tighten it. Do that with all the anchors.

Remove template boards from around pavilion.

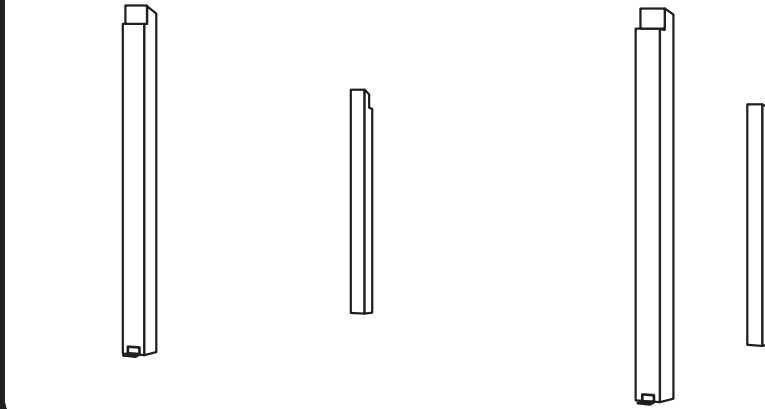

17

18



Slide post base on (thick trim down) then top trim (widest part facing up) over the top of all four posts.

Attach header between the two taller posts. Two lines will be marked on the header. The high notched side of the taller posts will sit between the two pencil marks. Attach to the posts using two 3 1/2" screws per post. Do not use the pre-drilled holes for these screws.

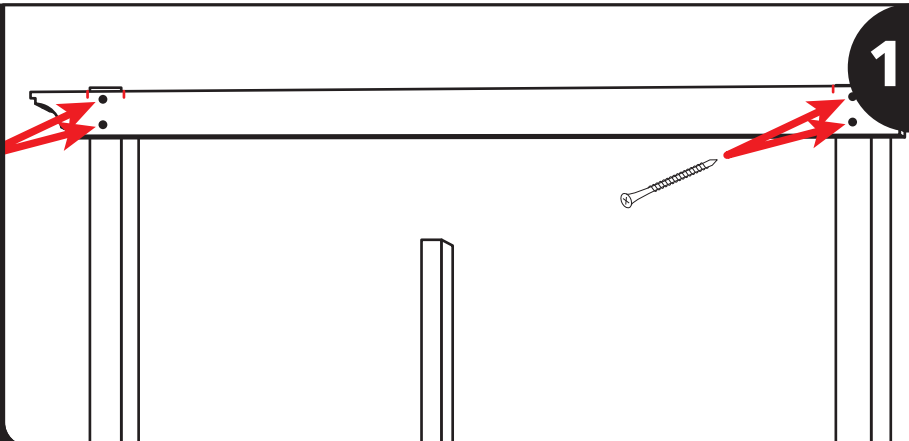

19

20

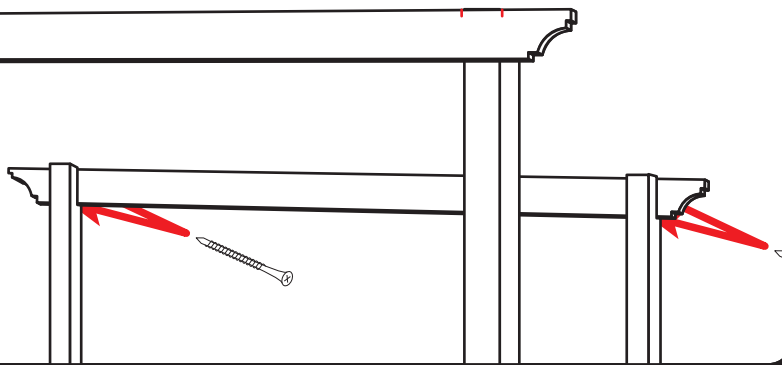

Repeat step 19 on with shorter posts.

Locate the two return beams. These will be connecting the lower post side to the taller post side.

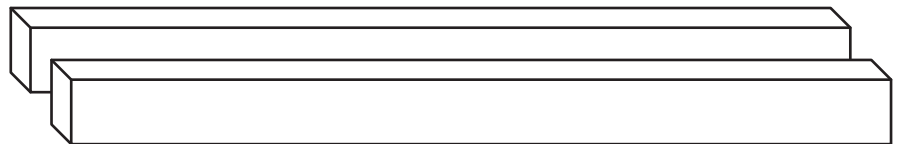

21

22

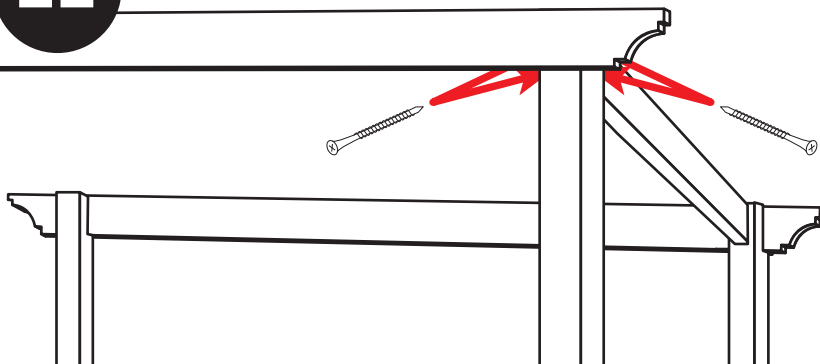

While the return beam is being held on both ends between the high side and the low side. Attach to the high side first, being sure to center the beam in the middle of the post and making the top of the beam flush with the top of the post. Attach with four 3 1/2" screws, two per side.

Attach the beam on the low side post, being sure to center the beam in the middle of the post and making the top of the beam flush with the top of the post, attach with four 3 1/2" screws, two per side."

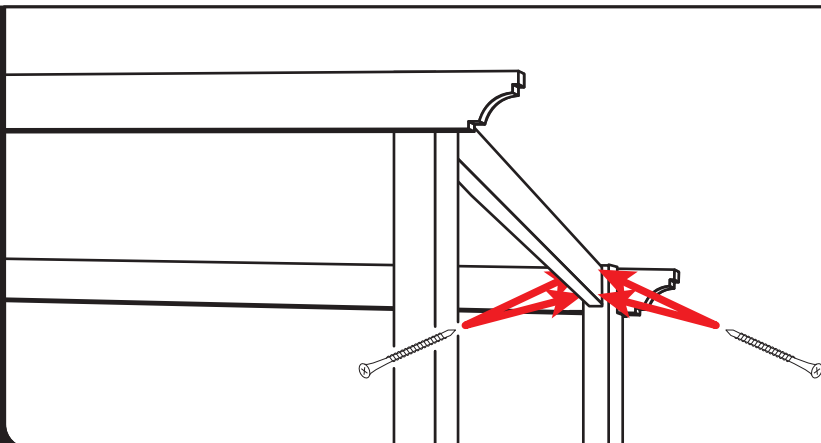

23

24

Repeat steps 22-23 on the other return beam side.

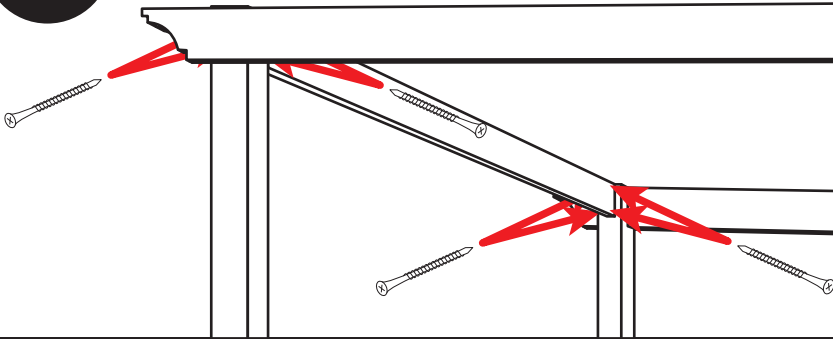

To finalize return beam installation, locate the eight 8" GRK screws. Send two GRK screws from the outside of the header into the return beams, using the pre-drilled holes. Repeat on all four posts.

AT ALL POSTS

25

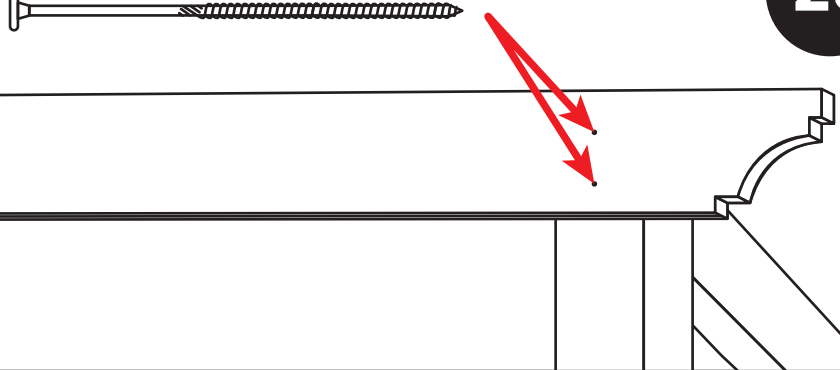

26

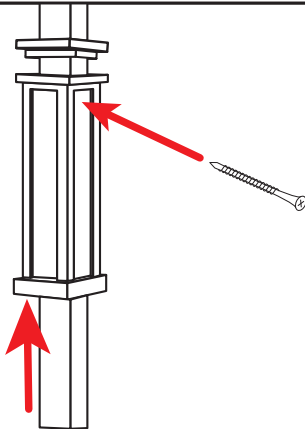

Slide post bases up 3' and attach with one 2 1/2" screw to hold in place."

Attach second L bracket to all posts. Both brackets placed on the outward sides of the post.

27

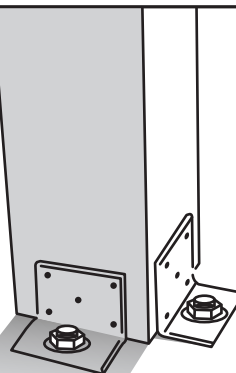

28

PUSH
4X



Unscrew post bases and lower into place.

Slide top trim piece against bottom of header, attach with two 2 1/2" screws into bottom of header, one on each opposite side.

29

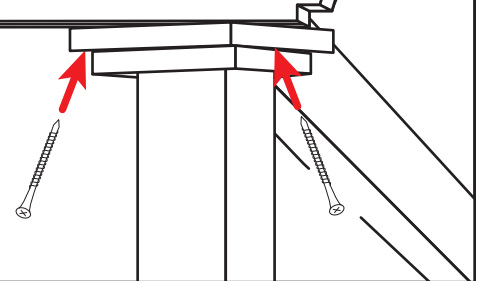

30

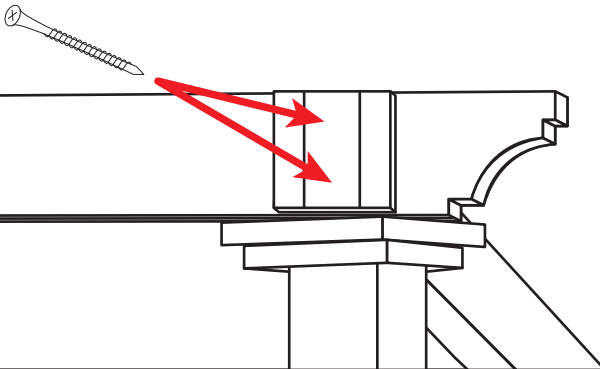

Locate header trim piece (4 total), center the first piece above top trim on the outside of the header and attach with two 2 1/2" screws. Repeat on all remaining posts on the outside of the header.

Locate all corner braces.

31

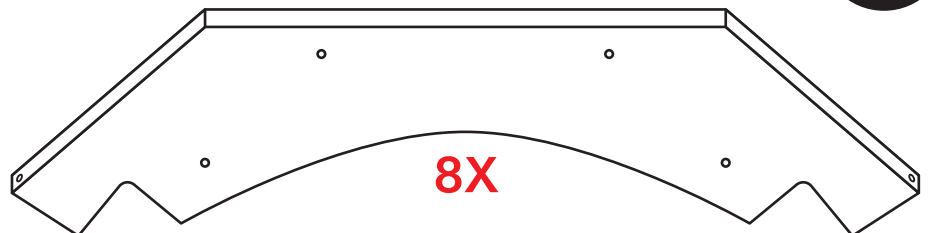

32

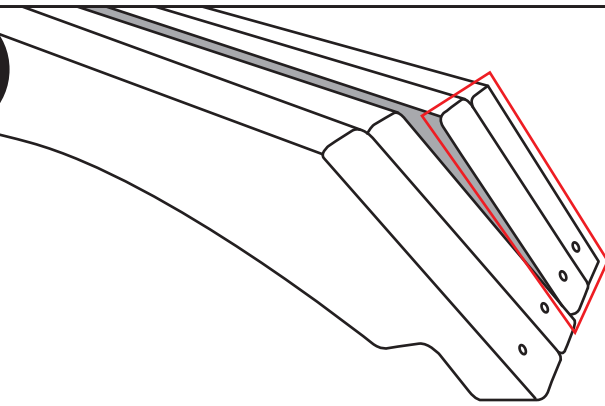

Lay them on the ground and choose the four braces that have the same angle at the top and the bottom. These will be used to support the two main headers (Front and back).

Locate the 5" black Timberlock screws (Based on wood type. The Pre-drilled hole amount will vary.)

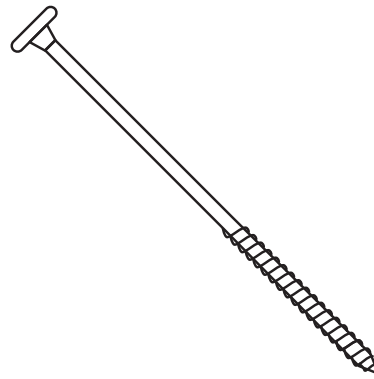

33

34

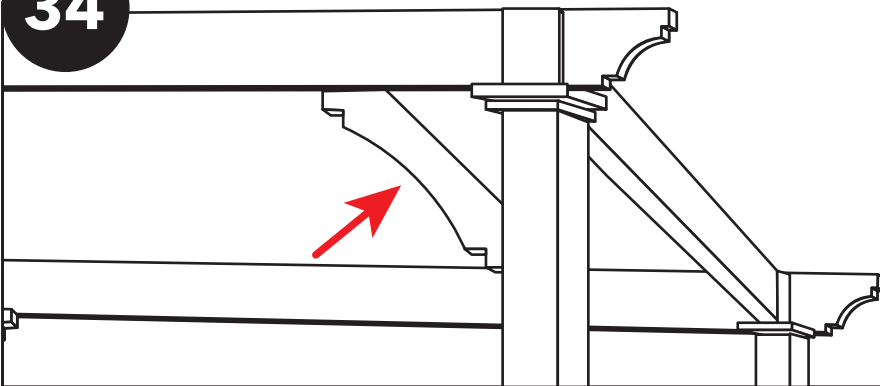

Hold the brace in place, being sure the top and bottom are flush with the header and the post and (for pressure treated: side attachment screws must face inward).

Keeping the brace flush on the post and the bottom of the header, attach it into the header through the pre-drilled holes with the 5" Timberlock screws.

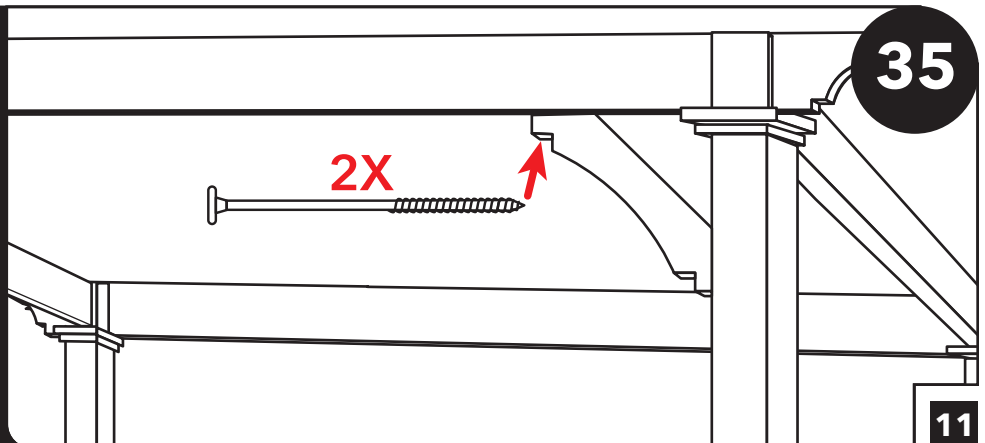

35

36

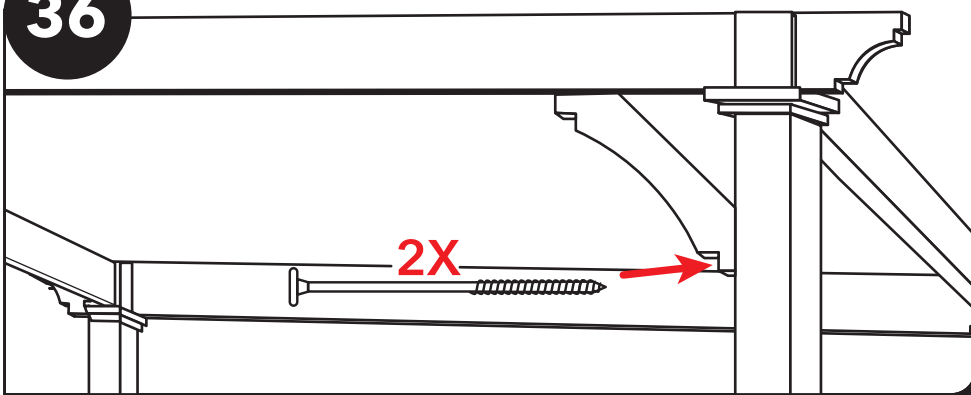

Keeping the brace flush with the outside of the post, attach the brace into the post through the pre-drilled holes with the 5" Timberlock screws.

Repeat this process with the remaining three braces on all sides for the main headers, front and back.

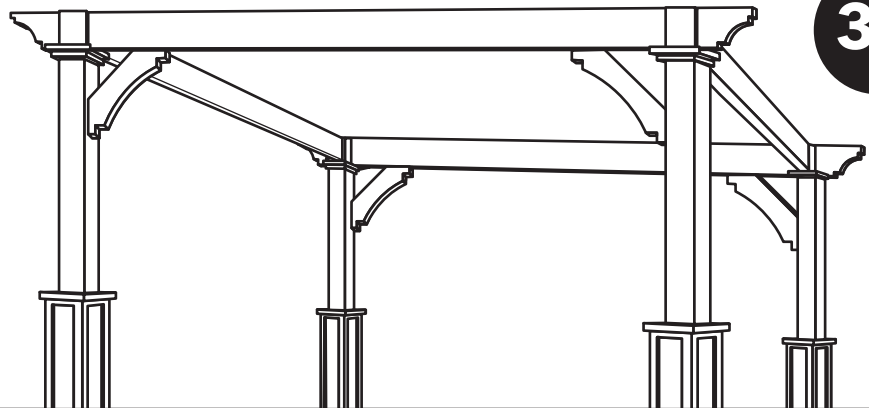

37

38

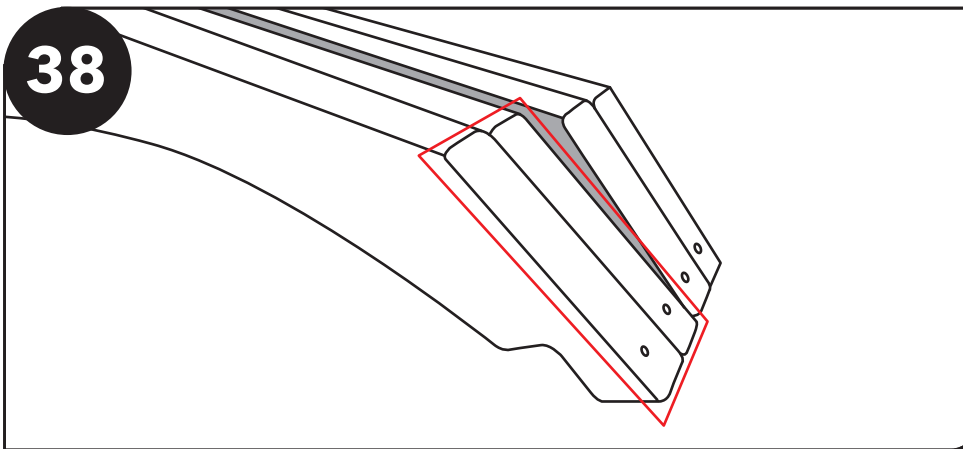

Locate the four braces with different angles cut on the top and bottom. based on the angles cut. **NOTE: When installing, if both ends are not flush before drilling, do not install. Find the brace that fits the angle. For pressure treated, be sure brace side screws are facing inside the pavilion.**

Keeping the brace flush on all sides on the bottom of the return beam, attach it into the beam through the pre-drilled holes with the 5" Timberlock screws.

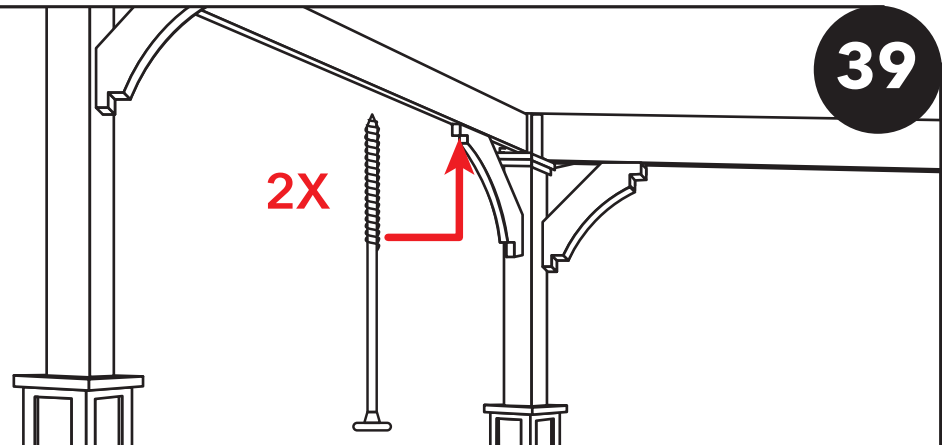

39

40

Keeping the brace centered on the post, attach the brace into the post through the pre-drilled holes with the 5" Timberlock screws.

Repeat this process with the remaining three braces on all sides for the return beams, left and right.

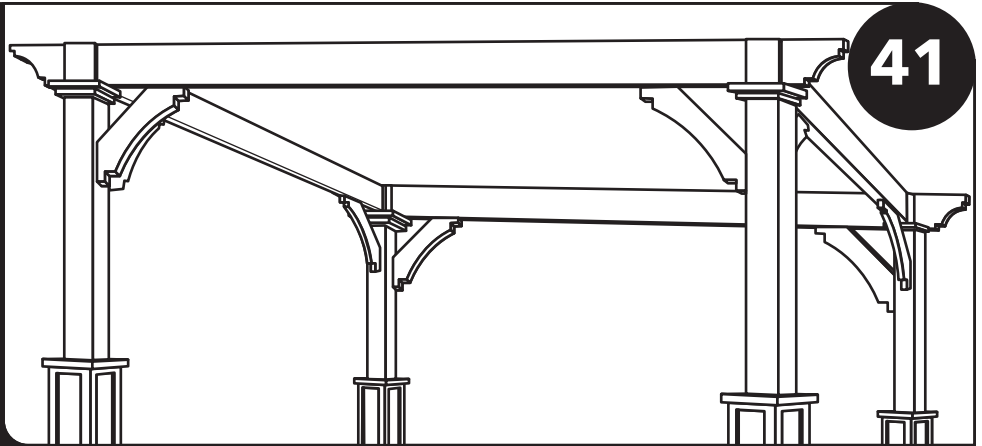
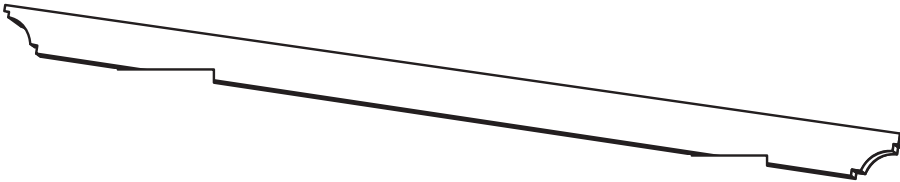
**41****42**

Locate the 2x6 rafters. The number of rafters will vary based on length of pavilion. Rafters will be notched on bottom in two places to sit flush on the top of header.

Place rafter on top of "X" marks being sure the side of the rafter is flush with the corresponding line. Be sure rafter seats into place where notched.

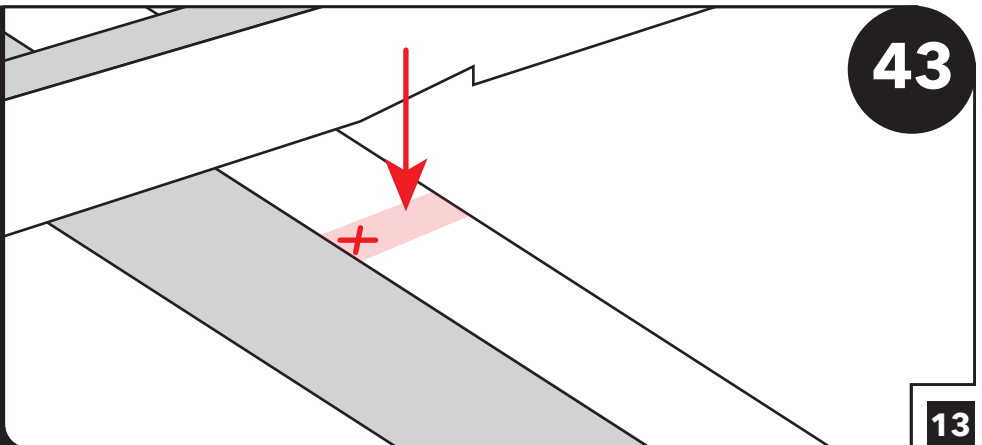
**43**

44

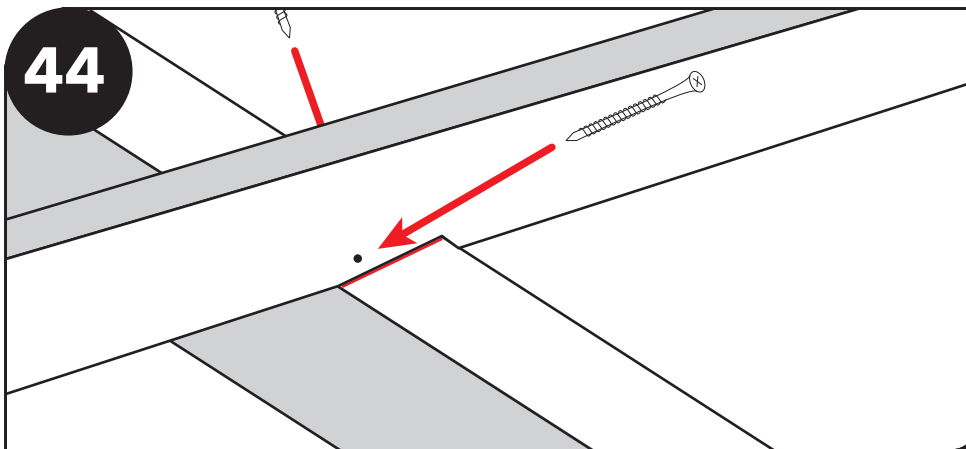

Attach rafter to high side header with two 3 1/2 " screws into pre-drilled holes. One on each side.

Repeat on low side header with the same rafter, being sure to work left to right after each rafter is individually attached.

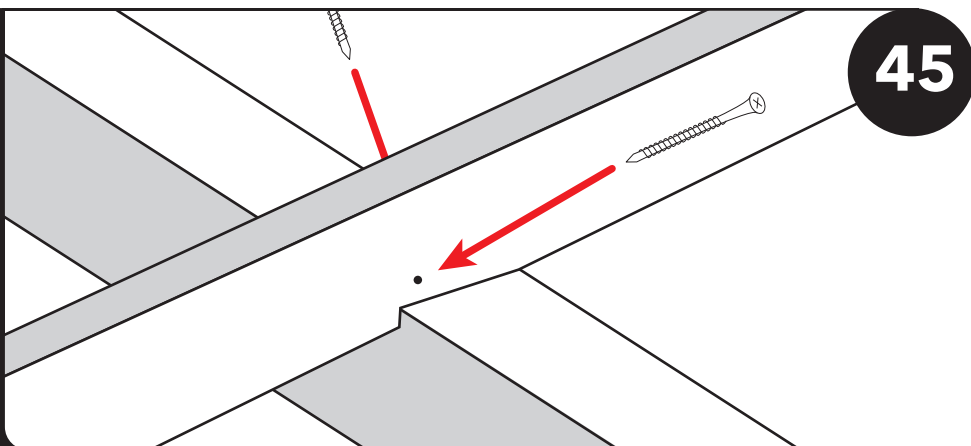

45

46

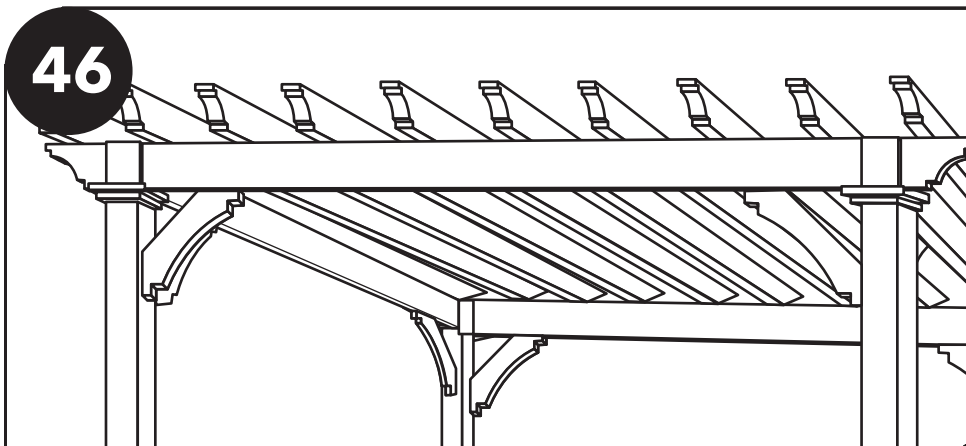

Continue the process until all rafters are attached.

Attach the rafters into the high side header from the top down with one 8" GRK screw.

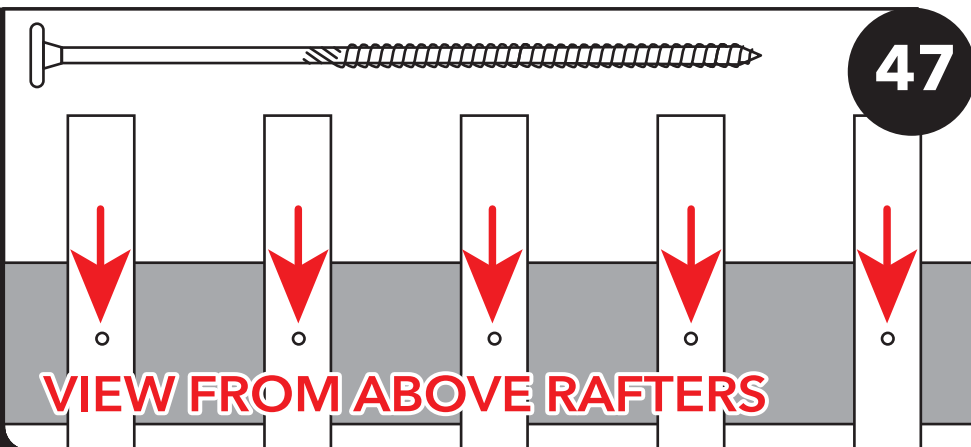

47

VIEW FROM ABOVE RAFTERS

48

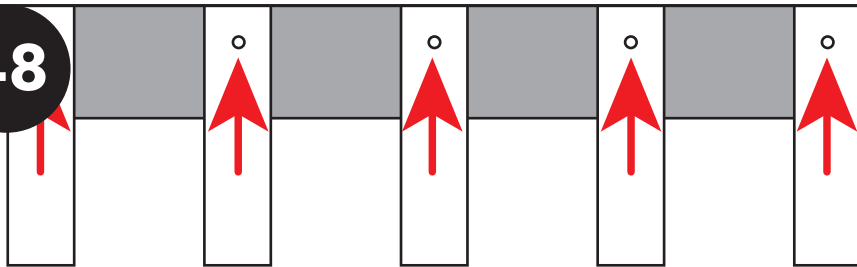

VIEW FROM ABOVE RAFTERS

Attach the rafters into the low side header from the top down with one 8" GRK screw.

You are now ready to installed the roof decking boards. **NOTE: If pavilion ceiling was stained. Stain side of board must face downward.**

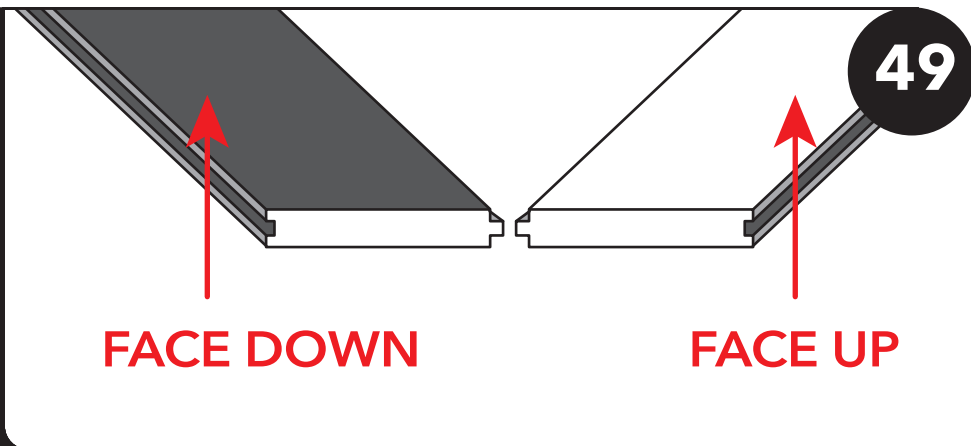

50

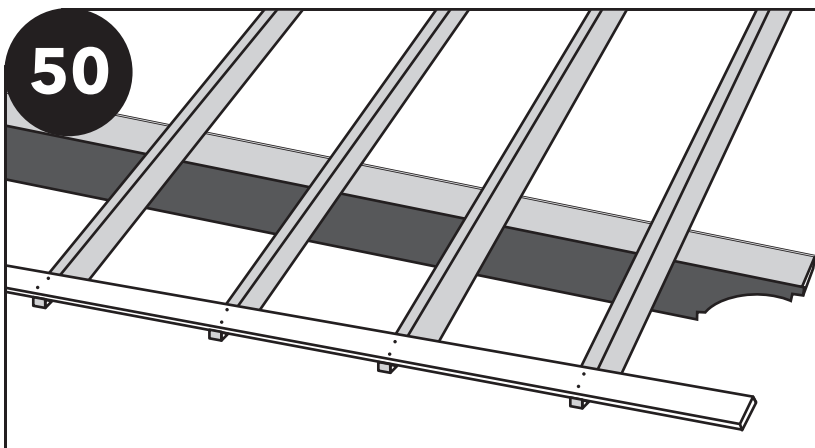

Place first board on low side of pavilion. Groove side facing away from the structure, tongue side facing toward the remaining boards.

Center board on pavilion. Measure on left and right outer side of rafters to be sure board overhangs equally on both sides.

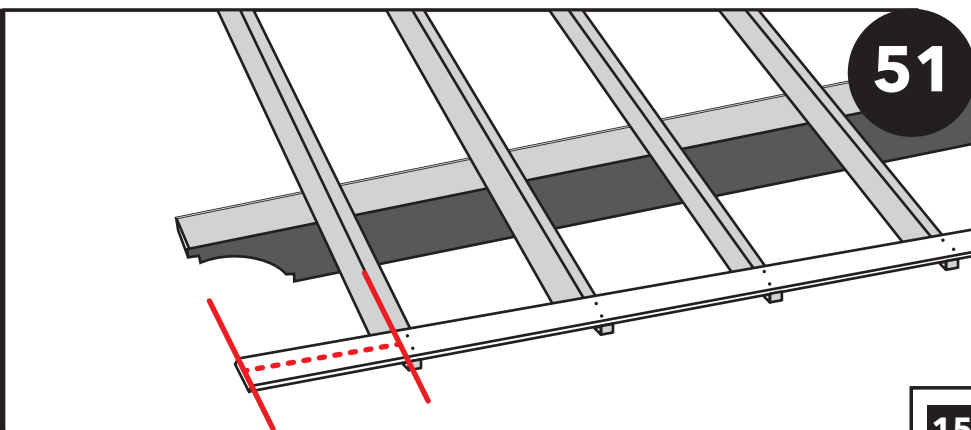

51

52

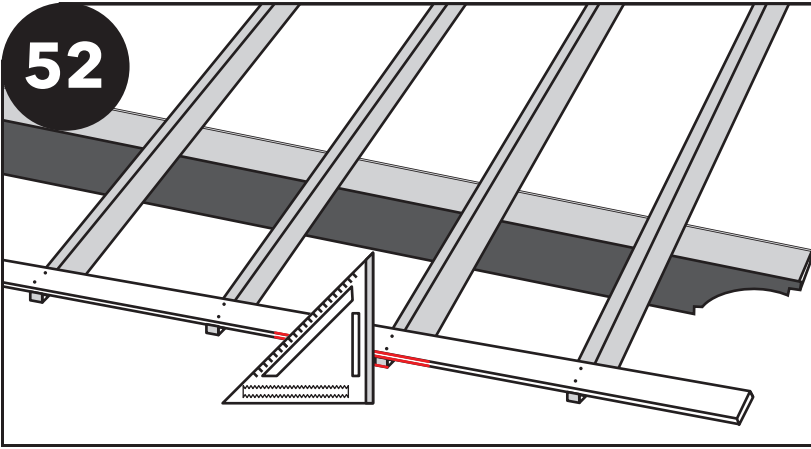

VERY IMPORTANT: Be sure first decking board is flush with the ends of the rafters, so the remaining boards attach squarely.

Fasten decking board from the top down, use two 2 1/2" screws per rafter.

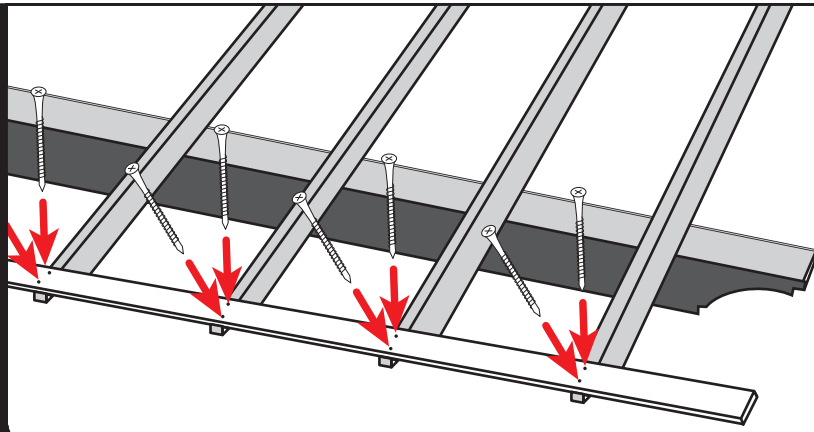

53

54

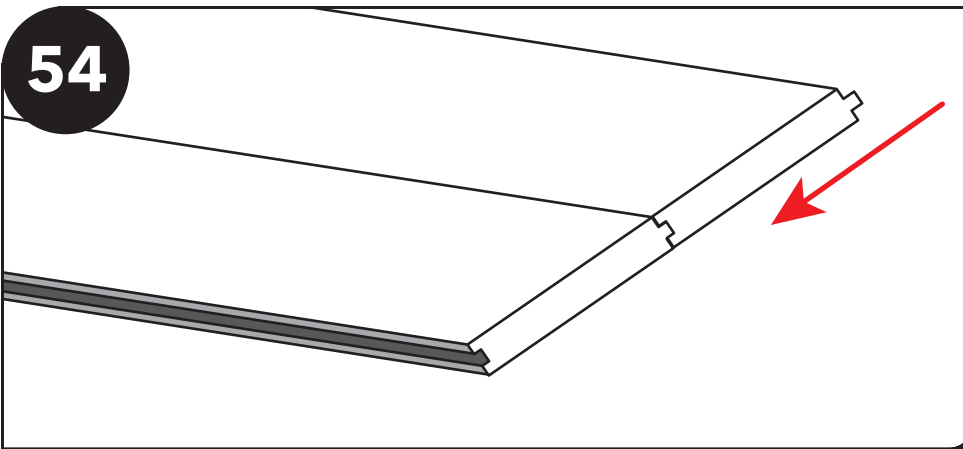

Tightly fit the next boards groove into the installed tongue board. **NOTE:** Be sure board is fully seated before screwing into place.

Repeat steps 51-54 until the last decking board needs to be installed. **NOTE:** The last board may need to be cut in order to fit.

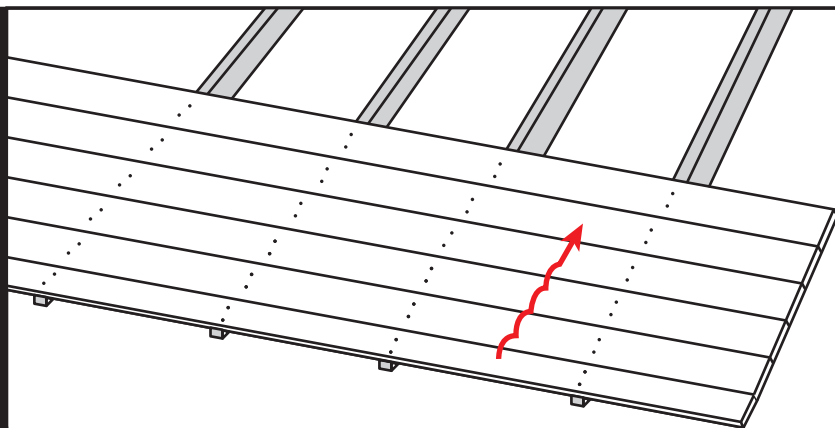

55

56

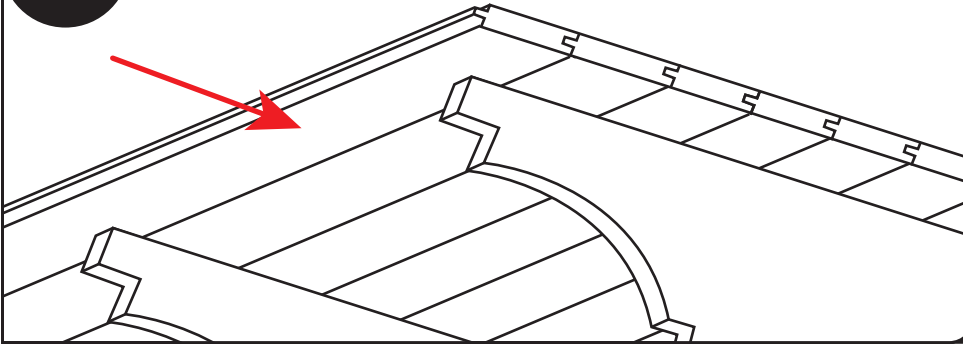

Fit last decking board tightly into place, but do not fasten. This board will completely cover all rafter ends.

Mark the underside of the board at the end of the last rafters on both sides.

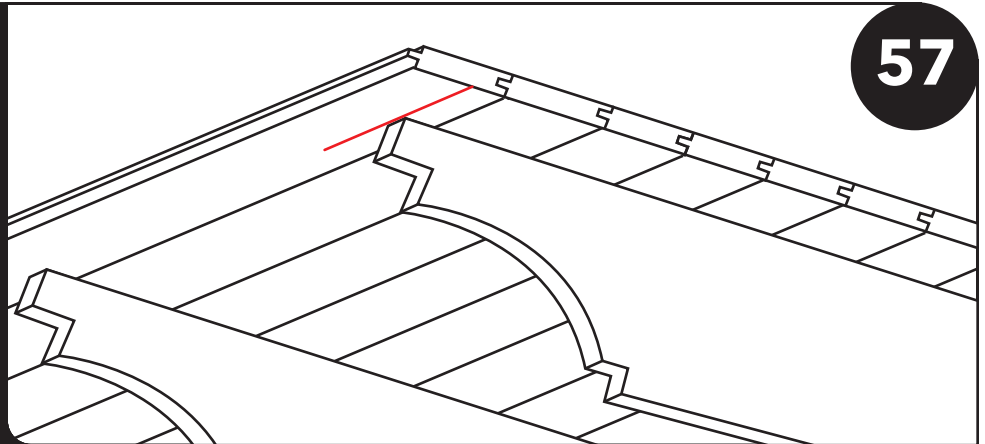

57

58

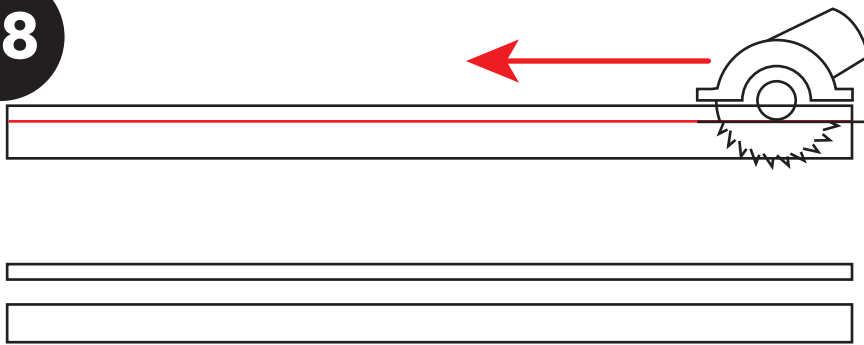

Use a straight edge to draw line and rip board accordingly.

Now reinstall board, fitting tightly and screw in two 2 1/2" screws at each rafter.

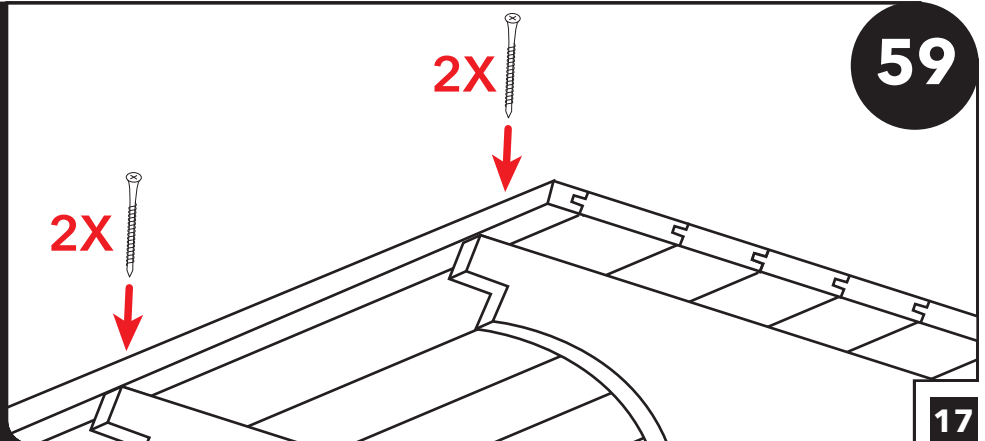

59

60

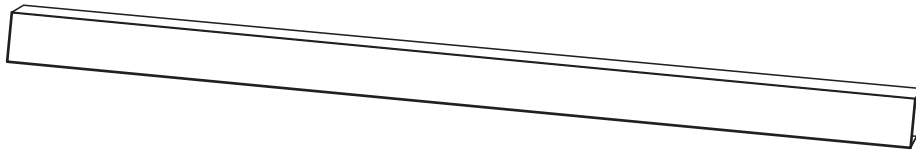

Locate all the 1x3" boards. These will be attached in the same direction as the roof decking.

Fasten first piece of roof lath, keeping 1/8"-1/4" away from the bottom edge of the roof decking. Attach lath with one 2 1/2" screw at each rafter. Be sure to not miss the rafter when screwing.

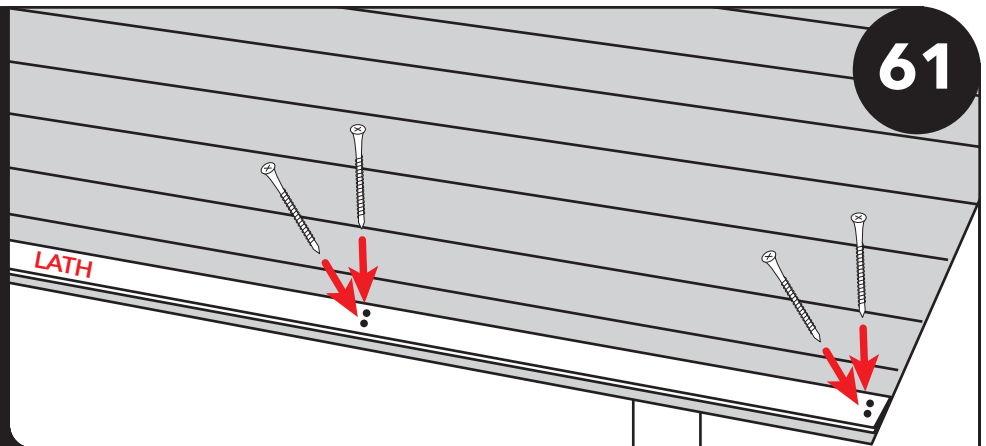

61

62

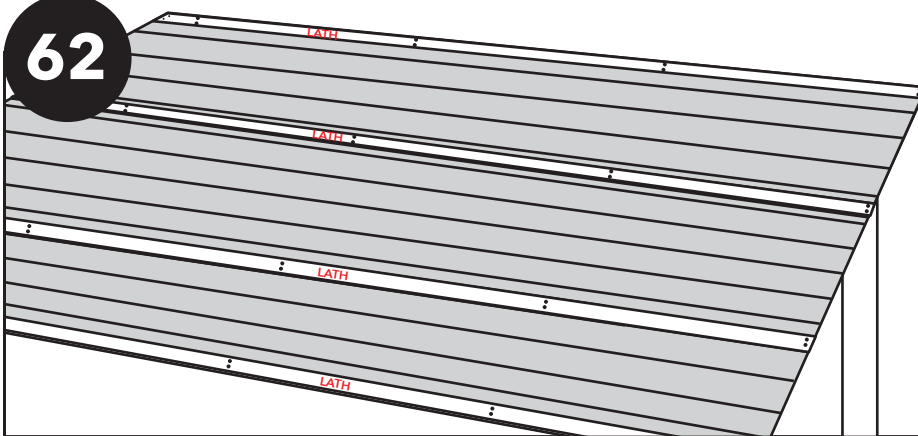

Repeat the process spacing each lath 20" - 24" apart. The last lath piece must sit 1/8" - 1/4" away from the edge of the roof decking.

Install the front drip edge. Place drip edge on top of the lath. Keep flush with edge of roof. Fasten with one 1 1/4" stainless steel screw every 24" and one final screw at the end.

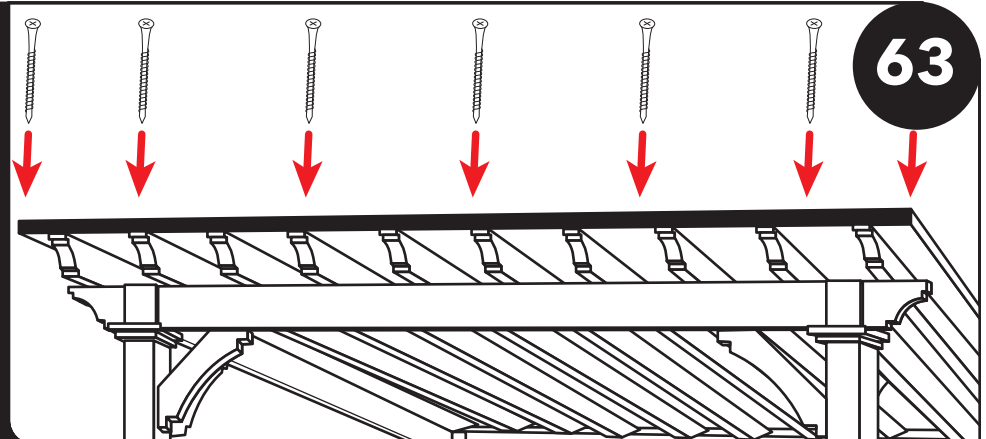

64

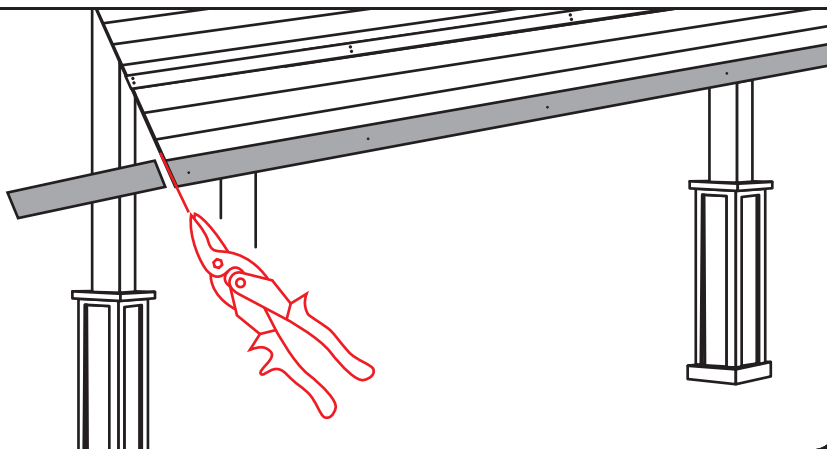

Using tin snips, cut drip edge accordingly. a

Install left side drip edge. Attach with 1 1/4" stainless steel screw on top of each lath piece. Cut to size at ends.

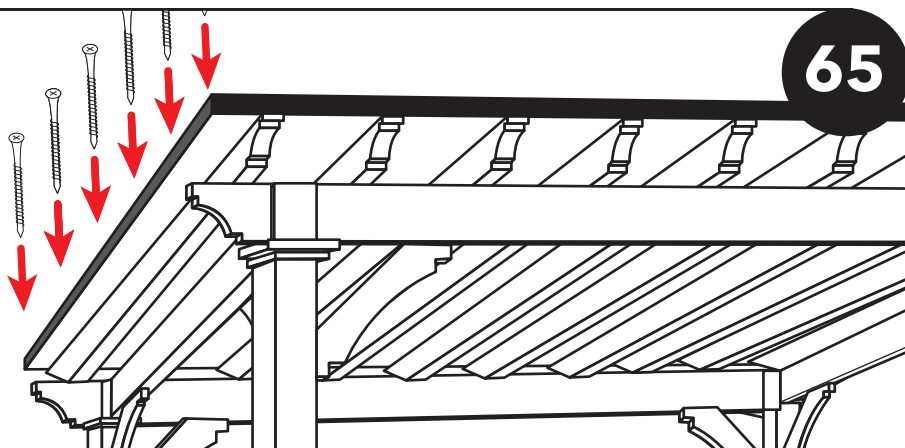

65

66

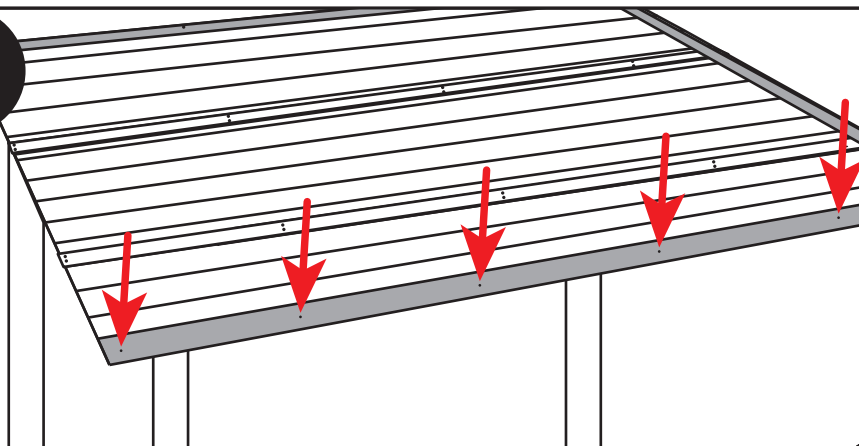

Install the back drip edge. Place drip edge on top of the lath. Keep flush with edge of roof. Fasten with one 1 1/4" stainless steel screw every 24" and one final screw at the end. Cut to size with tin snips.

Install final piece of drip edge on right side. Attach with 1 1/4" stainless steel screw on top of each lath piece. Cut to size at ends.

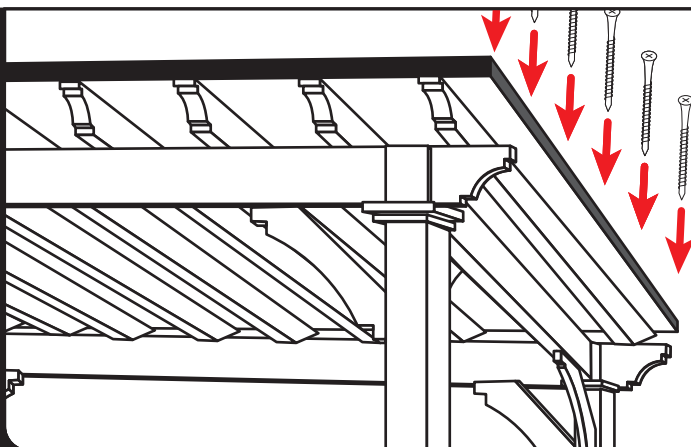

67

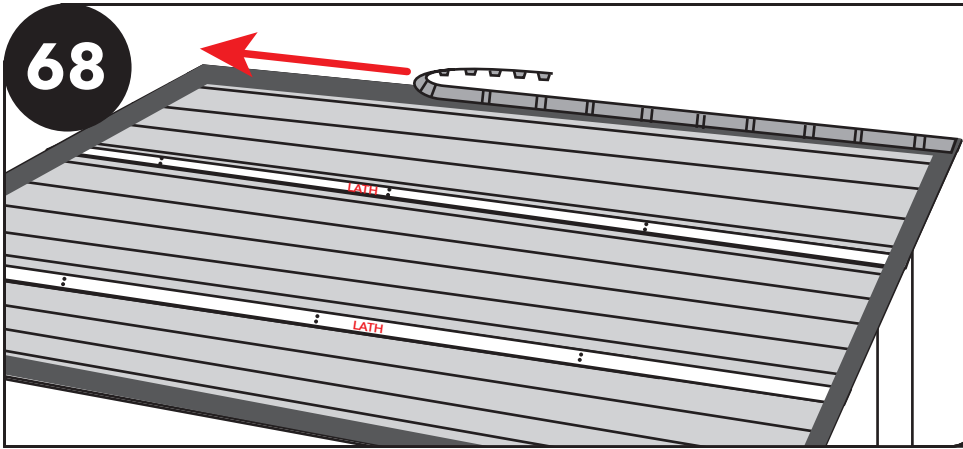

68

Locate Ribbing. Remove adhesive protection. Install the ribbing roughly 1 1/2" - 2" from the bottom of the drip edge on the front side. Do not stretch the ribbing, because the grooves of the roof must line up with the ribs.

Repeat Step 68 on the back edge.

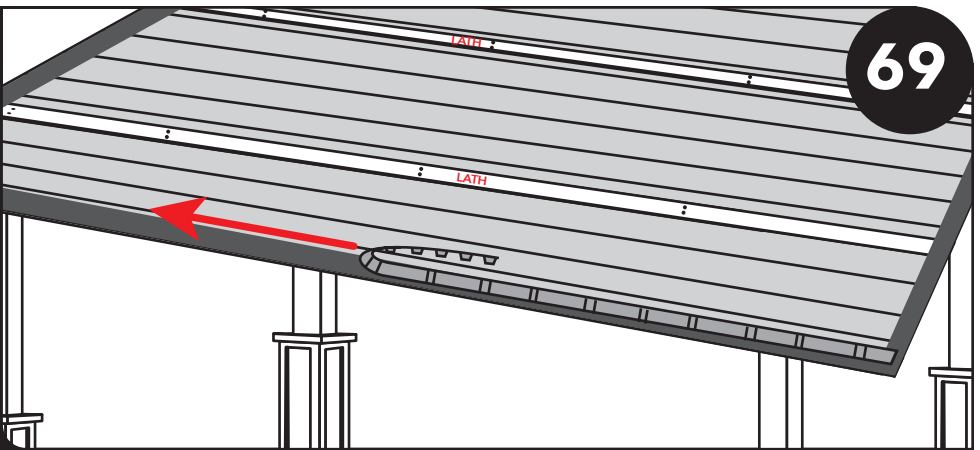

69

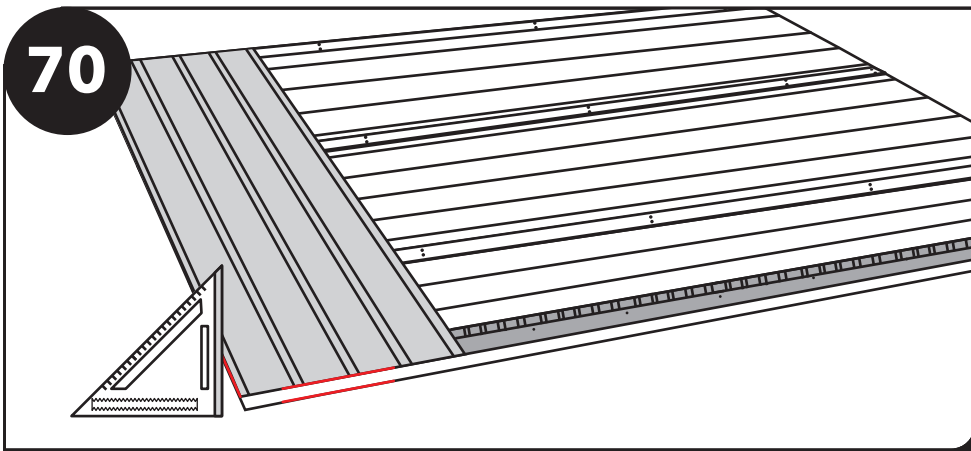

70

Install the roofing, starting on the right side and moving left. Ensure the first piece is installed squarely. It must be flush on the ends and on the side.

Attach with 1" roofing screws. The first piece will have three screws at every lath.

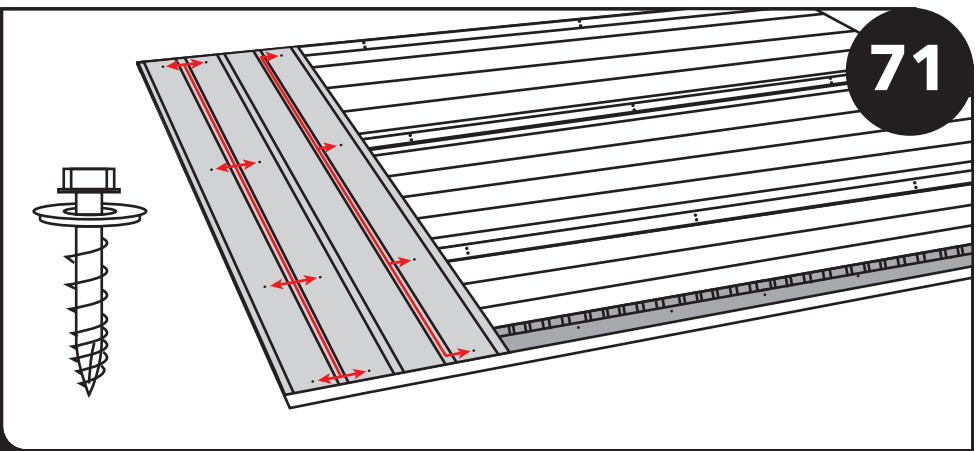

71

72

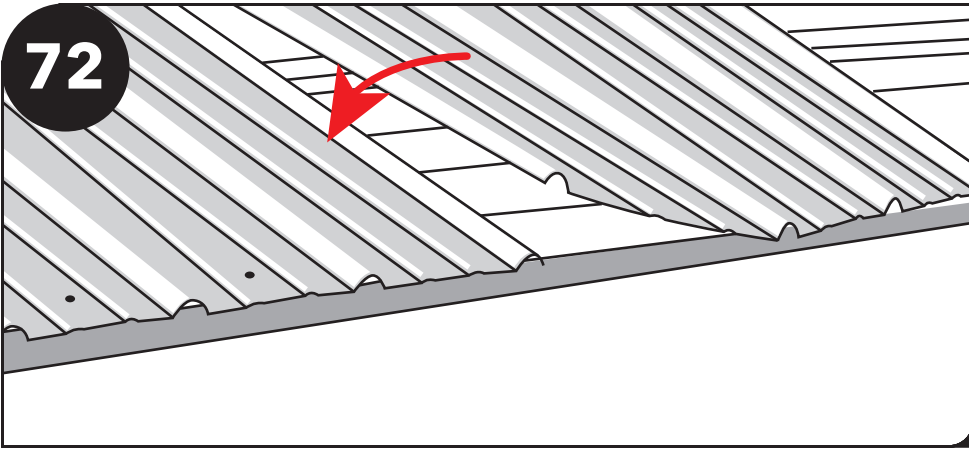

The next piece must properly overlap on the far edge. Attach with 1" roofing screws at the lath.

Last piece may need to be cut to size to be flush with the edge of the roof.

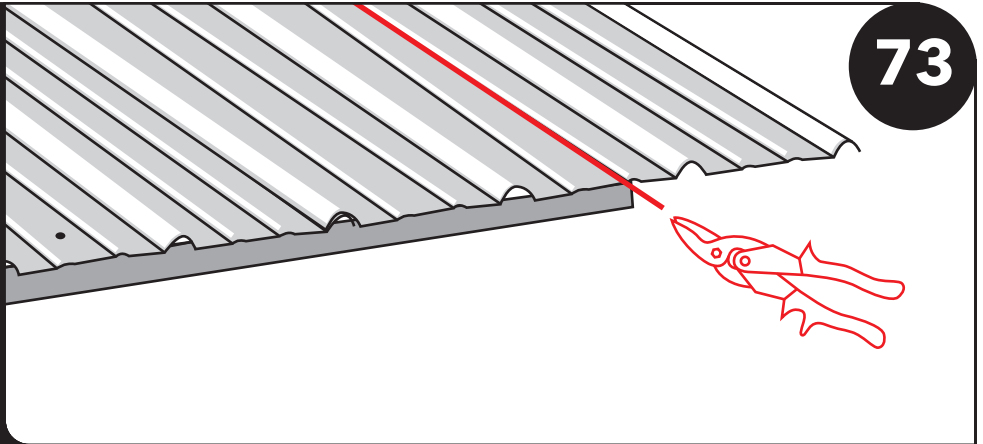

73

